

WAFER BALL VALVE ADLER TYPES FA1/FA2**NACE****Certificate 3.1**Lloyd's
Register

ISO 9001 : 2015

Lloyd's
Register

PED/2014/68/UE

**FIRE SAFE**
ISO 10497

Size : DN 15 to 250 mm
Ends : Between flanges PN16/40
Min Temperature : - 28°C
Max Temperature : + 200°C
Max Pressure : 40 Bars up to DN80, 16 bars over
Specifications : With ISO 5211 mounting pad
Fire safe according to ISO 10497
Contents ball
Atex

Materials : Forged Carbon steel A105

WAFER BALL VALVE ADLER TYPES FA1/FA2

SPECIFICATIONS :

- Full bore
- Anti blow-out stem
- With ISO 5211 mounting pad
- Wafer type
- Between flanges R.F. PN40 up to DN80, PN16 over
- Double antistatic device
- Fire safe according to ISO 10497 (ISO-FT marking)
- Contents ball with removable body
- With exhaust hole in the ball from DN50 to DN250 (located in the top of the ball to avoid overpressure in it)
- Machining of the seat for pressure relief DN65 to DN250 (respect the flow direction indicated by the arrow)
- Threaded flanges holes
- Fugitive emissions according to ISO 15848-1 : 2003 Class A
- 3 PTFE filled with graphite chevrons rings on stem
- Packing with elastic rings
- Polyamid epoxy painting blue color RAL5012, 35 µ thickness

USE :

- Chemical and pharmaceutical industries, petrochemical industries, hydraulic installation, compressed air
- Min and max Temperature Ts : - 28°C to + 200°C
- Max Pressure Ps : 40 bars up to DN80 , 16 bars over
- Vacuum : 10⁻⁵ torr
- Compressed air (ambient temperature) : 10 bars up to DN50, 8 bars from DN65 to 100
- Steam : 8 bars up to DN50, 6 bars from DN65 to 100

RANGE :

- Forged carbon steel body PN40 up to DN80 and PN16 over **Ref. 720** from DN 15 to DN 250 (*)
 - Possible with gear box IP67 **Ref. 9830260 to 264** from DN 15 to DN 250
- (*) : PN40 on request

ACCESSORIES AND OPTIONS :

- Locking device **Ref. 9830140 to 9830148** from DN 15 to DN 200
- Stainless steel handle **Ref. 9830170 to 9830178** from DN 15 to DN 200
- Steel oval handle **Ref. 9830271 to 9830272** from DN 15 to DN 32
- Stainless steel oval handle
- Stainless steel bolting
- Carbon steel stem extension 100 mm **Ref. 9830273 to 9830280** from DN 15 to DN 200
- Stainless steel stem extension 100 mm **Ref. 9830193 to 9830200** from DN 15 to DN 200
- Deadman **Ref. 9830160 to 9830165** from DN 15 to DN 50
- Dry cleaned oxygen **Ref. 9830150 to 9830155** from DN 15 to DN 200
- Standard dry cleaned
- Seat PTFE filled with glass, graphite, stainless steel or metal
- Pocket less seat PTFE or PTFE filled with glass
- Heating jacket carbon or stainless steel
- Specials coated
- Hole in the ball for overpressure device
- Double o ring on stem

ENDS :

- Between flanges PN40 up to DN80, PN16 over

WAFER BALL VALVE ADLER TYPES FA1/FA2

MATERIALS DN 15-40 (ADLER FA1 TYPE) :

PACKING GASKETS :

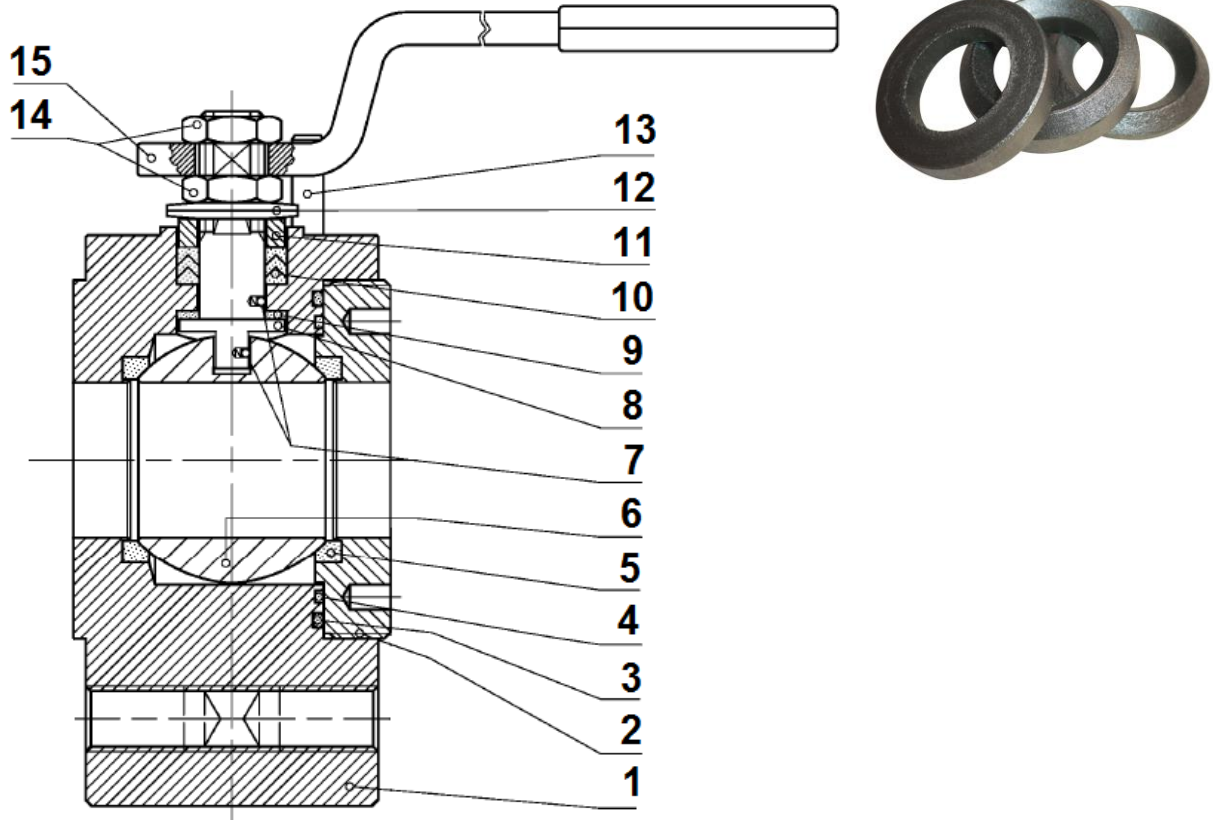

(* : Included in gaskets kit)

Item	Designation	Materials DN15-40	
1	Body	ASTM A105	
2	Ends		
3*	O ring	FKM	
4*	Body gasket	PTFE	
5*	Seat	PTFE	
6	Ball	ASTM A351 CF3	ASTM A351 CF3M
7	Double antistatic device	ASTM A479 S31600	
8	Stem	ASTM A182 F 316 L	
9*	Stem gasket	PTFE	
10*	Chevron packing	PTFE filled with 15% graphite	
11	Gland follower	ASTM A479 S31600	
12	Elastic ring	C72 / 50 Cr V4 galvanized	
13	Pin	UNI 3740 8.8 galvanized	
14	Nut	UNI 3740-6S galvanized	
15	Handle	UNI 5946 Fe 37 galvanized	

WAFER BALL VALVE ADLER TYPES FA1/FA2

MATERIALS DN 50-250 (ADLER FA2 TYPE) :

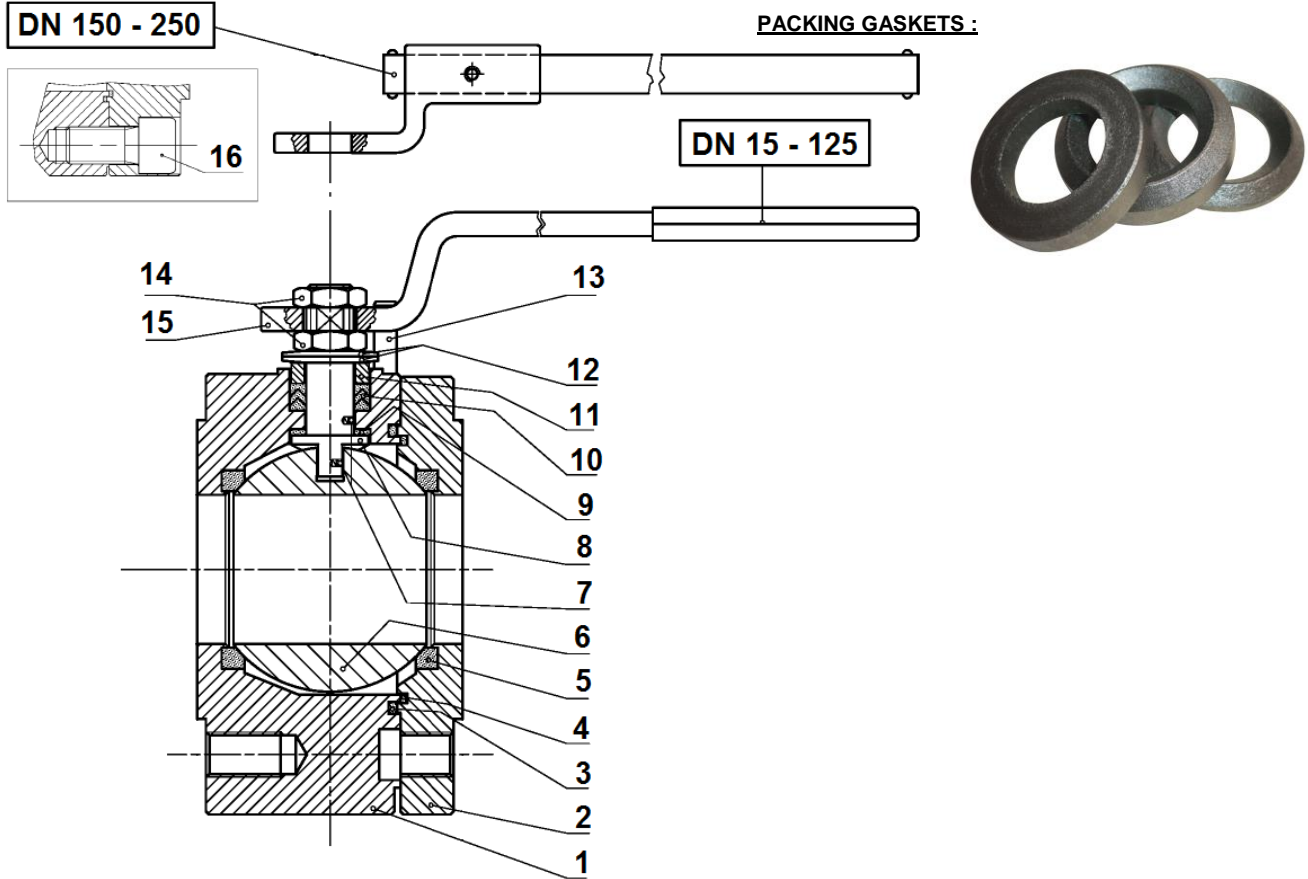

(* : Included in gaskets kit)

Item	Designation	Materials DN50-250
1	Body	ASTM A105
2	Ends	
3*	O ring	FKM
4*	Body gasket	PTFE
5*	Seat	PTFE
6	Ball	ASTM A351 CF3
7	Double antistatic device	ASTM A479 S31600
8	Stem	ASTM A479 304L
9*	Stem gasket	PTFE
10*	Chevron packing	PTFE filled with 15% graphite
11	Gland follower	ASTM A479 S31600
12	Elastic ring	C72 / 50 Cr V4 galvanized
13	Pin	UNI 3740 8.8 galvanized
14	Nut	UNI 3740-6S galvanized
15	Handle	UNI 5946 Fe 37 galvanized
16	Screw	UNI 3740 8.8 galvanized

WAFER BALL VALVE ADLER TYPES FA1/FA2

GEARBOX MATERIALS :

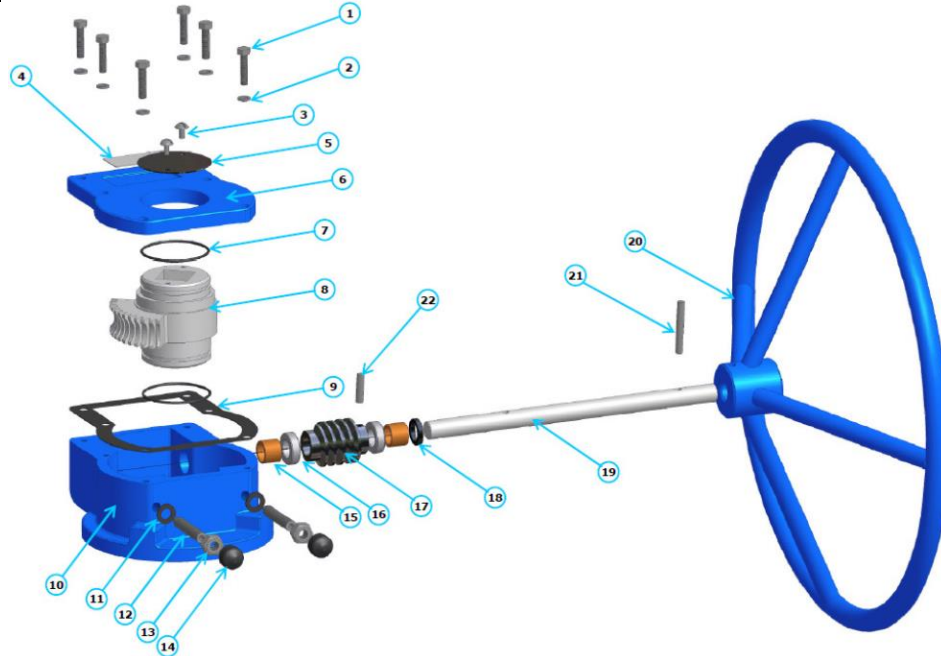

Item	Designation	Materials Ref. 9830260 to 9830264
1	Box screw	DIN 933 class 8.8
2	Washer	C72
3	Indicator screw	DIN 86 class A2
4	ID plate	Steel S235 JR
5	Indicator	Steel S235 JR
6	Cover	Ductile iron EN GJS-400-15
7	O ring	NBR 70 Shore A
8	Wheel	Ductile iron EN GJS-500-7
9	Cover gasket	SL509AT
10	Box	Ductile iron EN GJS-400-15
11	Gasket	NBR 70 Shore A
12	Adjusting bolt	DIN 915 class 12.9
13	Nut	DIN 934 class 8G
14	Bolt cap	NBR 70 Shore A
15	Bushing	G Cu Sn10
16	Axial ball bearing	-
17	Worm	C45 + NiP
18	Gasket	NBR 70 Shore A
19	Input shaft	C45 + NiP
20	Handwheel	Steel S235 JR
21	Dowell pin	DIN 7 Class A2
22	Dowell pin	DIN 7 Class A2

WAFER BALL VALVE ADLER TYPES FA1/FA2

SIZE DN 15 – 40 FA1 TYPE (in mm) :

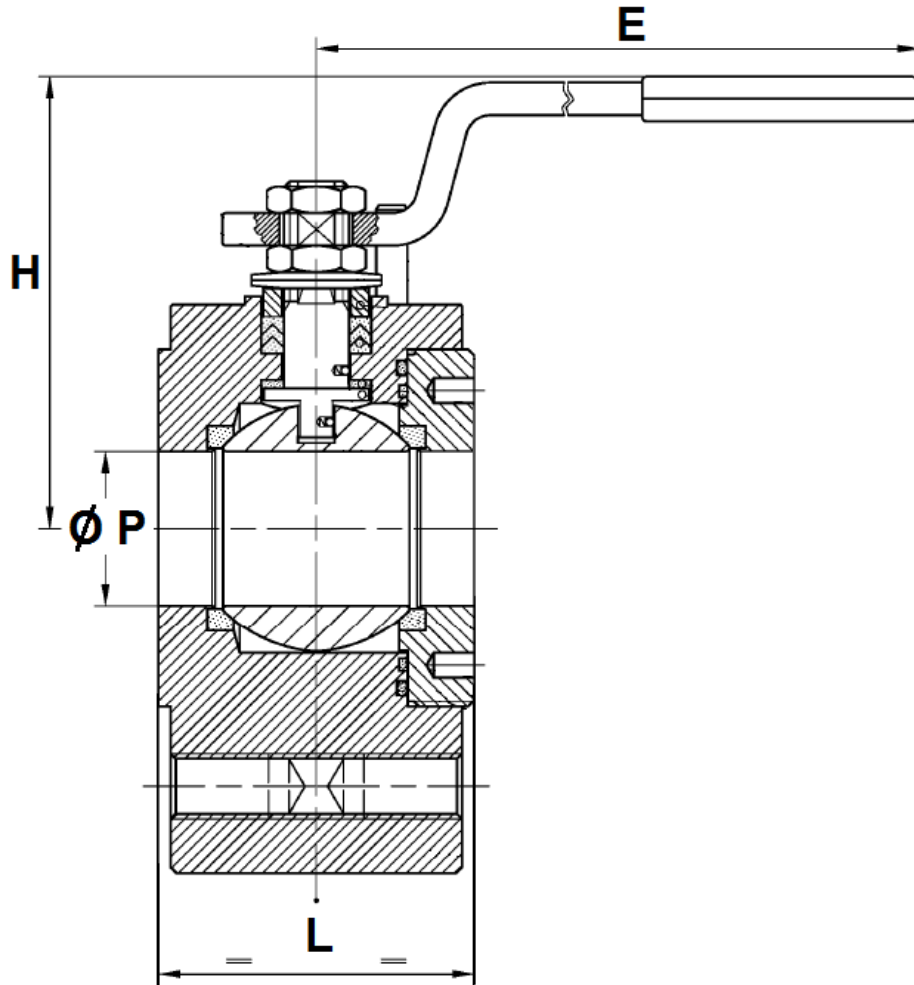

Ref.	DN	15	20	25	32	40
720 FA1	Ø P	15	19	25	30	38
	L	35	37	43	51	64
	E	145	145	185	185	280
	H	66	68	85	91	110
	Weight (Kg)	1.6	1.9	2.8	4.8	7.2

WAFER BALL VALVE ADLER TYPES FA1/FA2

SIZE DN 50 - 250 FA2 TYPE (in mm) :

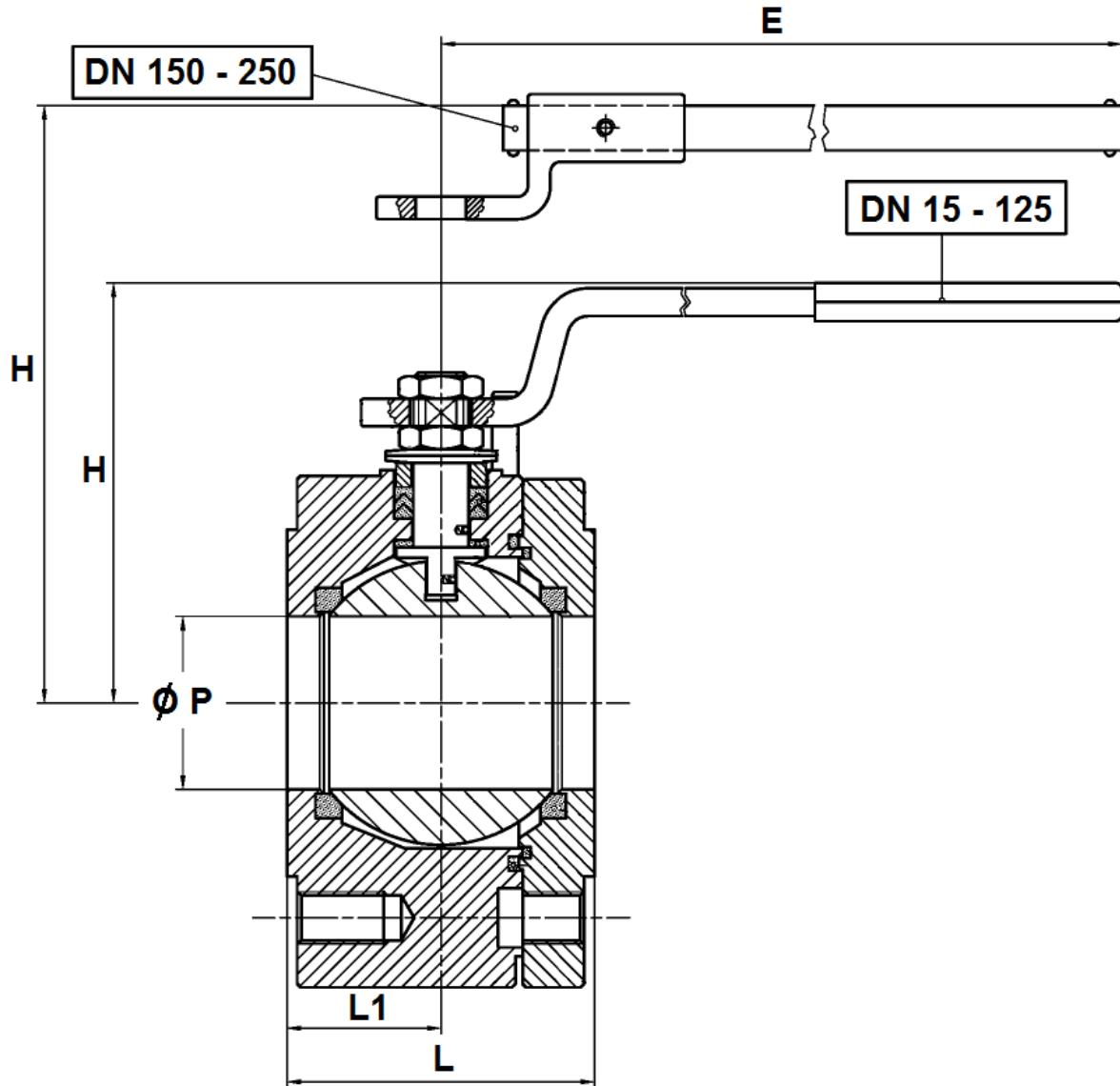

Ref.	DN	50	65	80	100	125	150	200	250
720 FA2	Ø P	51	64	76	101	118	152	203	254
	L	84	103	120	154	182	234	310	314
	L1	42.5	51.5	60	77.5	91	117	155	157
	E	280	370	370	470	650	750	900	1000
	H	120	144	152	174	188	256	294	343
	Weight (Kg)	11.5	18	23.5	35	51	90	121	180

WAFER BALL VALVE ADLER TYPES FA1/FA2

STEM AND ISO MOUNTING PAD SIZE DN 15 – 40 FA1 TYPE (in mm) :

DN 15 – 40 (FA1 TYPE)

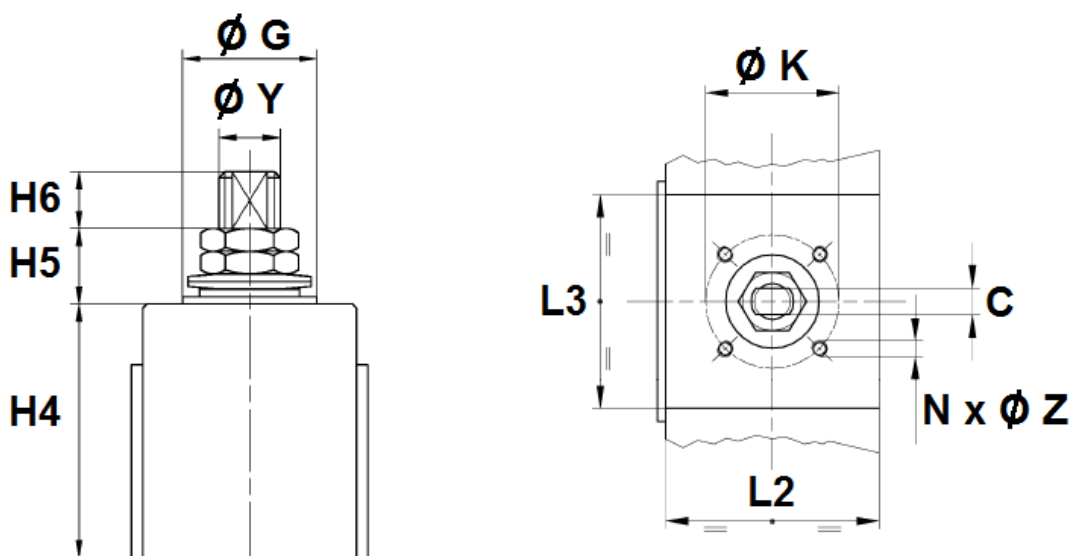

DN	15	20	25	32	40
H4	32.5	35	41	46.5	55
H5	7.5	7.5	16.5	16.5	19.5
H6	7	7	10	10	10
C	6	6	8	8	10
Ø Y	10	10	12	12	16
Ø K	36	36	36	36	50
ISO	F03	F03	F03	F03	F05
N x Ø Z	4 x M5	4 x M5	4 x M5	4 x M5	4 x M6
Ø G	25	25	25	25	35
L2	33	33	40	48	58
L3	69	78	81	105	102

WAFER BALL VALVE ADLER TYPES FA1/FA2

STEM AND ISO MOUNTING PAD SIZE DN50-250 FA2 TYPE (in mm) :

DN 50 – 250

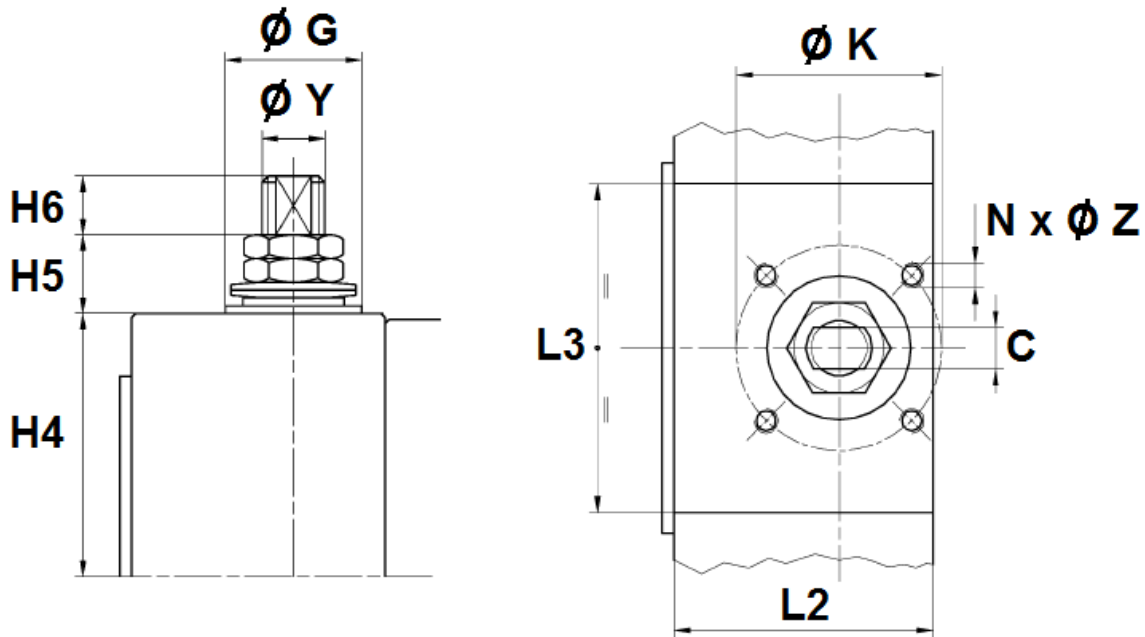

DN	50	65	80	100	125	150	200	250
H4	65	82	90.5	99.5	114	144	182	225.5
H5	21	24	24	27	26	34	37	40
H6	10	12	12	17	18	19	20	20
C	10	14	14	18	18	28	32	36
Ø Y	16	22	22	30	30	42	48	56
Ø K	50	70	70	70	102	125	140	165
ISO	F05	F07	F07	F07	F10	F12	F14	F16
N x Ø Z	4 x M6	4 x M8	4 x M8	4 x M8	4 x M10	4 x M12	4 x M16	4 x M20
Ø G	35	55	55	55	70	85	100	130
L2	62	79	88	105	133	150	228	257
L3	102	85	80	86	112	110	95	150

WAFER BALL VALVE ADLER TYPES FA1/FA2

FLANGES THREADED HOLES SIZE (in mm) :

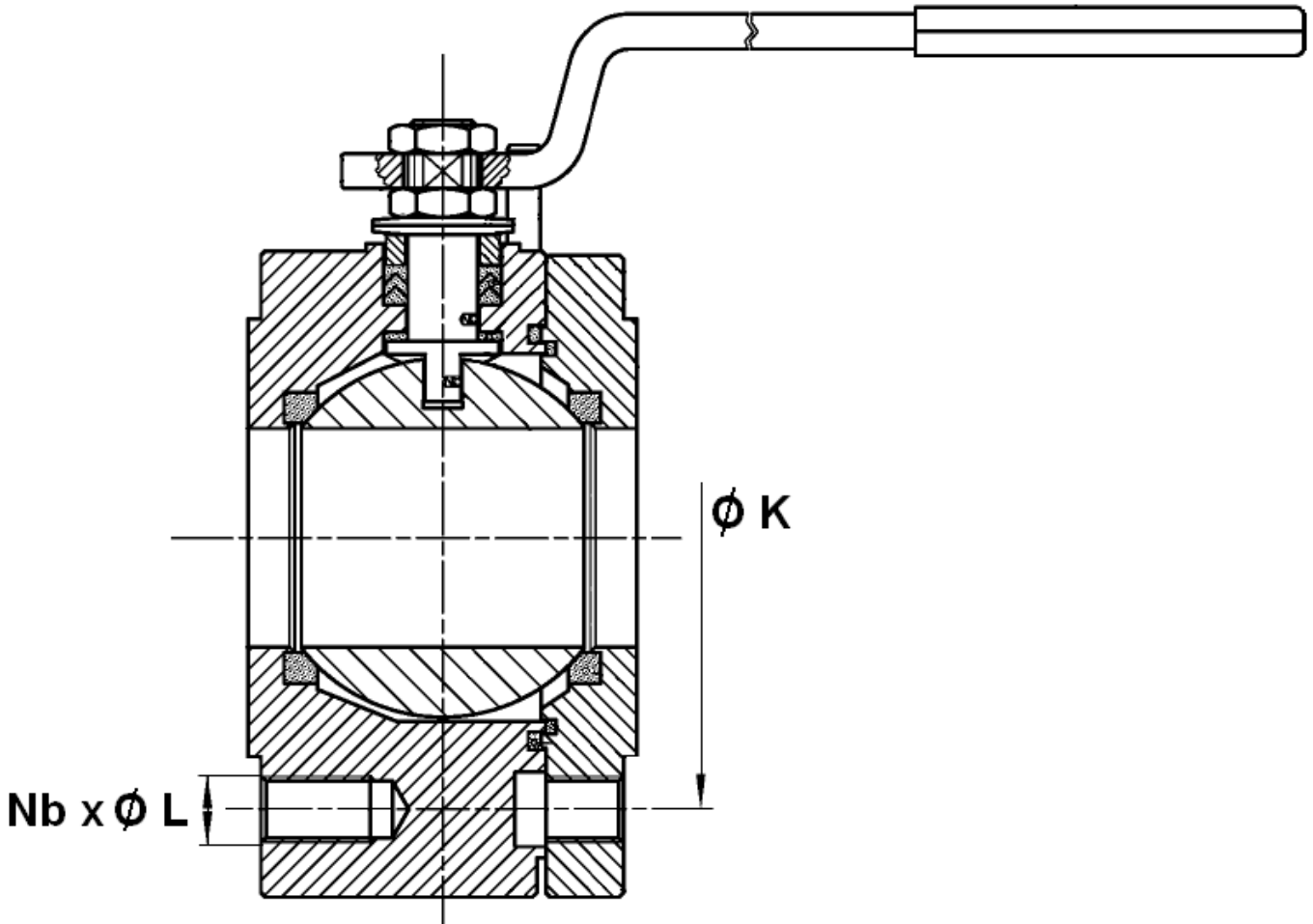

DN	15 (PN40)	20 (PN40)	25 (PN40)	32 (PN40)	40 (PN40)	50 (PN40)	65 (PN16)	65 (PN40)	80 (PN40)	100 (PN16)	125 (PN16)	150 (PN16)	200 (PN16)	250 (PN16)
Ø K	65	75	85	100	110	125	145	145	160	180	210	240	295	355
Nb x Ø L	4 x M12	4 x M12	4 x M12	4 x M16	4 x M16	4 x M16	4 x M16	8 x M16	8 x M16	8 x M16	8 x M16	8 x M20	12xM20	12xM24
Suggested screw length	30	35	35	40	40	40	40	45	45	40	45	45	50	65

WAFER BALL VALVE ADLER TYPES FA1/FA2

DEADMAN SIZE (in mm) :

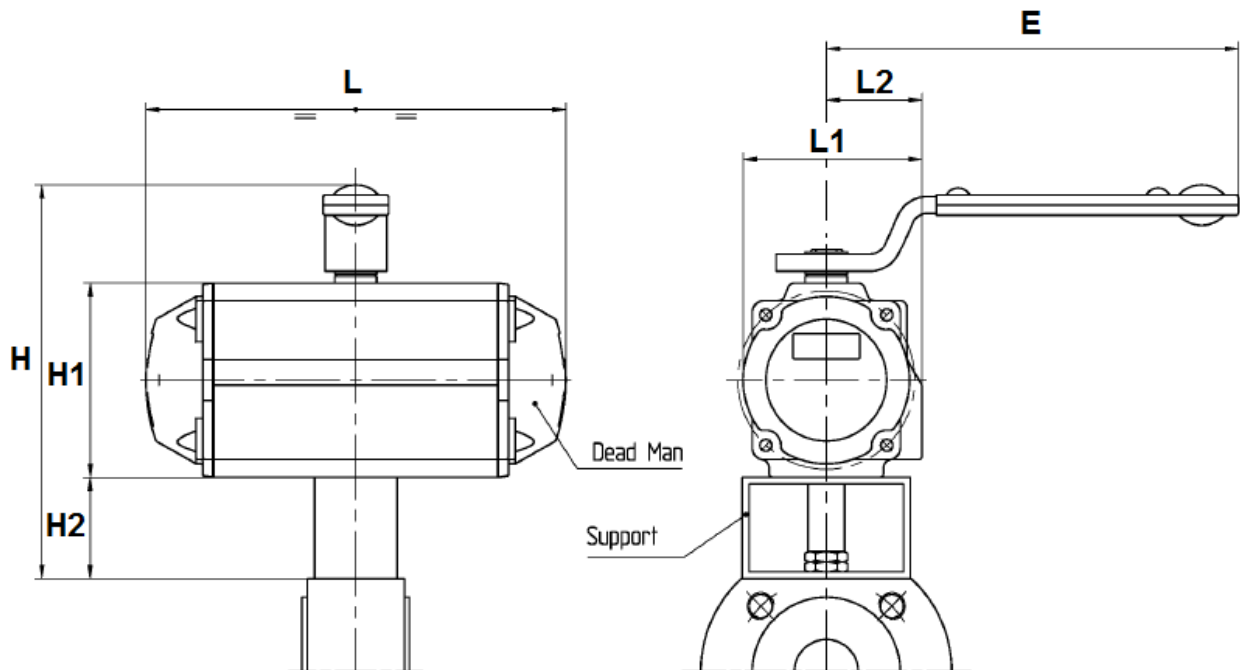

DN	15	20	25	32	40	50
Ref.	9830160	9830161	9830162	9830163	9830164	9830165
L	142	142	161	161	214	252
L1	70.5	70.5	83.5	83.5	94	105
L2	41.5	41.5	47.5	47.5	51	55.5
E	185	185	185	185	280	370
H	157	157	169	169	215	233
H1	69	69	85	85	102	115
H2	40	40	40	40	60	60

WAFER BALL VALVE ADLER TYPES FA1/FA2

GEARBOX SIZE (in mm) :

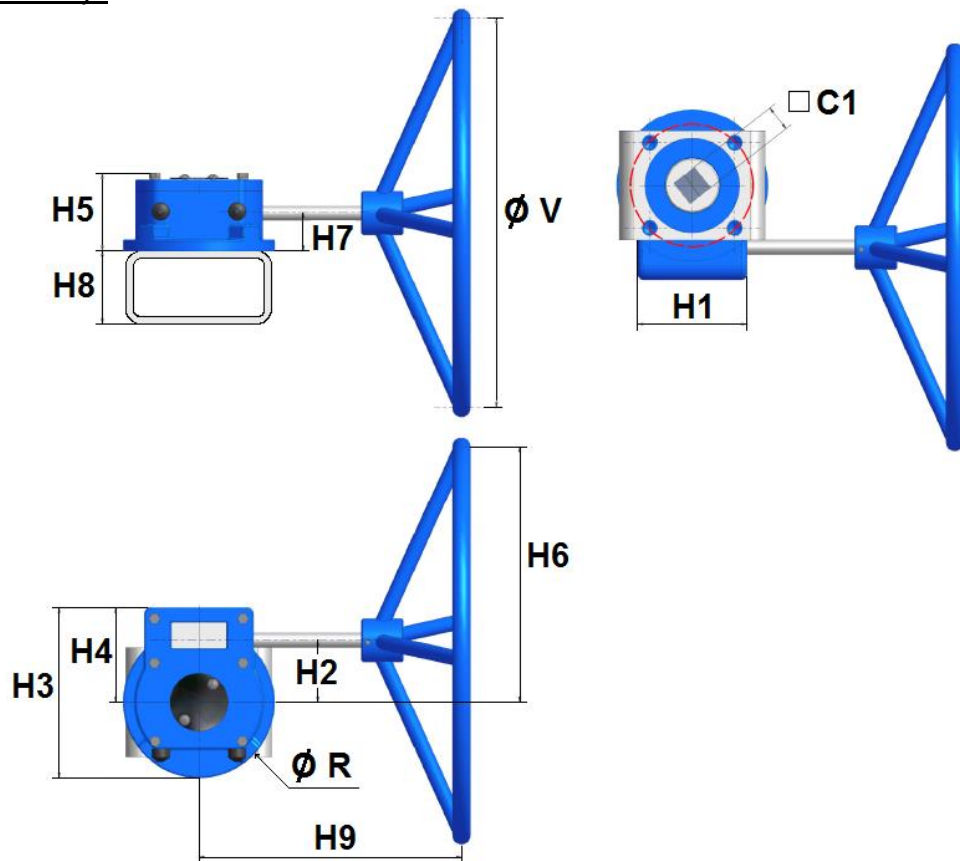

DN	15-50	65-80	100-150	200	250
C1	22	22	22	27	36
H1	57	57	100	120	150
H2	46	46	55	74	96
H3	98	98	143	188	237
H4	50.5	50.5	79.5	99	129.5
H5	56	56	73	97	106
H6	106	146	205	274	396
H7	34	34	35	48	55
H8	60	60	80	80	100
H9	117	131	250	274	365
Ø R	98	98	143	188	237
Ø V	120	200	300	400	600
Weight (Kg)	2.2	2.3	4.5	9.1	18.2
Ref.	9830260	9830261	9830262	9830263	9830264

WAFER BALL VALVE ADLER TYPES FA1/FA2
GEARBOX SPECIFICATIONS :

DN	15-50	65-80	100-150	200	250
Ref.	9830260	9830261	9830262	9830263	9830264
Ratio factor	40 :1	40 :1	37 :1	34 :1	38 :1
Input torque (Nm)	35	34	43	83	152
Output torque (Nm)	100	150	500	1000	2000

BOLT TIGHTENING TABLE (FOR FLANGES) (in Nm) :

DN	15	20	25	32	40	50	65	80	100	125	150	200	250
THREADED	M12	M12	M12	M16	M16	M16	M16	M16	M16	M16	M20	M20	M24
Torque (Nm) for carbon steel bolting	84.8	84.8	84.8	205	205	205	205	205	205	205	400	400	691
Torque (Nm) for stainless steel bolting	53	53	53	128	128	128	128	128	128	128	250	250	432

TORQUE VALUES (in Nm without safety coefficient) :

DN	15	20	25	32	40	50	65	80	100	125	150	200	250
Torque (Nm) PN16	5.4	10.8	13.5	16	31	40	66	78	140	158	340	510	800
Torque (Nm) PN40	6.5	12.5	14.5	18	33	44	72	88	156	230	520	610	1060

We recommend a safety coefficient of 2 to choose the actuator

WAFER BALL VALVE ADLER TYPES FA1/FA2**STANDARDS :**

- Fabrication according to ISO 9001:2015
- DIRECTIVE 97/23/CE : CE N° 0038
Risk category III module H
- Certificate 3.1 on request
- Designing according to BS EN 12516-2
- Construction according to ISO 14313
- Materials according to NACE MR 01-75
- Pressure tests according to EN 12266-1, rate A
- Marking according to EN 19
- Fire safe according to ISO 10497:2004
- Fugitive emissions according to ISO 15848-1 : 2003 A Class
- SIL3 according to IEC/EN 61508 (on request)
- ISO 5211 mounting pad
- Flanges according to EN 1092-1 PN16/40
- Length according to EN 558-6 series 100
- ATEX Group II Category 2 GDc TX Zone 1 & 21 Zone 2 & 22 (optional marking)
- On request, ATEX Group II Category 1G/Dc TX Zone 0 & 20

ADVICE : Our opinion and our advice are not guaranteed and SFERACO shall not be liable for the consequences of damages.
The customer must check the right choice of the products with the real service conditions.

WAFER BALL VALVE ADLER TYPES FA1/FA2**INSTALLATION INSTRUCTIONS****GENERAL GUIDELINES :**

- Ensure that the valves to be used are appropriate for the conditions of the installation (type of fluid, pressure and temperature).
- Be sure to have enough valves to be able to isolate the sections of piping as well as the appropriate equipment for maintenance and repair.
- Ensure that the valves to be installed are of correct strength to be able to support the capacity of their usage.
- **Installation of all circuits should ensure that their function can be automatically tested on a regular basis (at least two times a year).**

INSTALLATION INSTRUCTIONS :

- **Before installing the valves, clean and remove any objects from the pipes** (in particular bits of sealing and metal) which could obstruct and block the valves.
- **Ensure that both connecting pipes either side of the valve (upstream and downstream) are aligned (if they're not, the valves may not work correctly).**
- **Make sure that the two sections of the pipe (upstream and downstream) match, the valve unit will not absorb any gaps. Any distortions in the pipes may affect the tightness of the connection, the working of the valve and can even cause a rupture.** To be sure, place the kit in position to ensure the assembling will work.
- **If sections of piping do not have their final support in place, they should be temporarily fixed. This is to avoid unnecessary strain on the valve.**
- Tighten the bolts in cross.
- It's recommended to operate the valve (open and close) 1 to 2 times per year